

H. A. REMINGTON.  
Let-Off Mechanism for Looms.

No. 161,901.

Patented April 13, 1875.

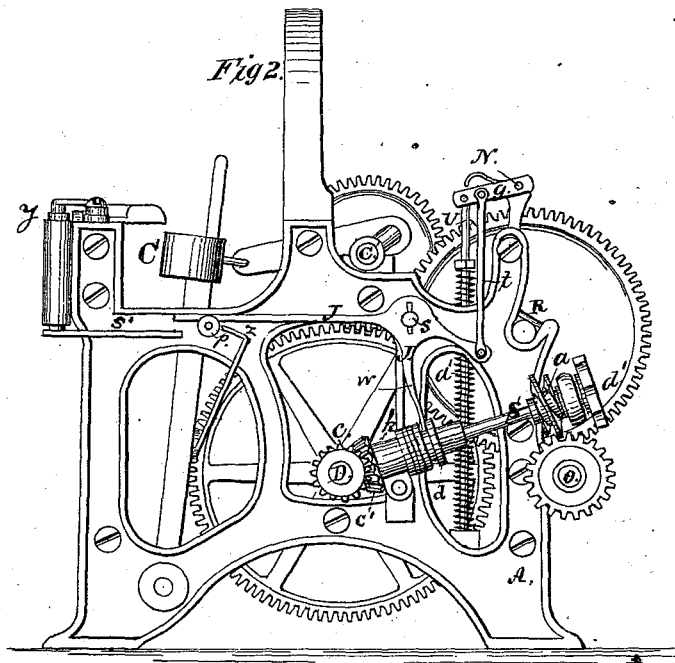
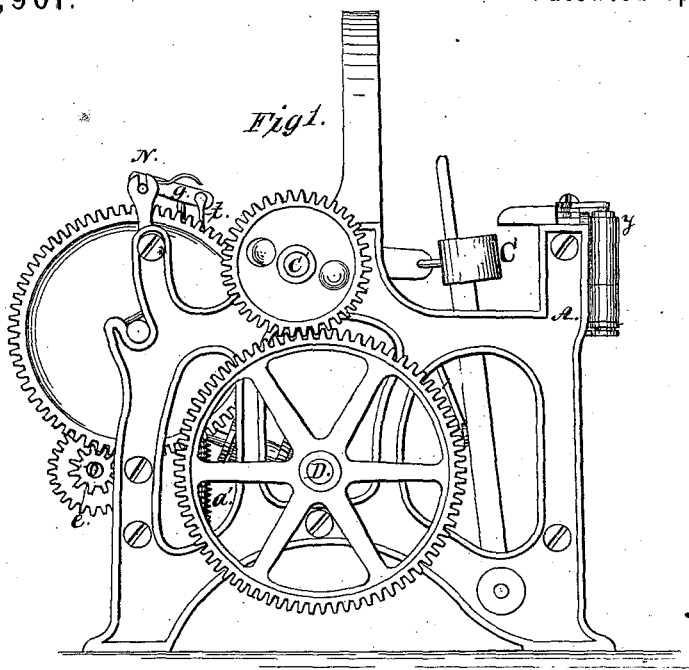

Witnesses:

Lawton S. Johnson  
Wm. C. Brayson

Inventor:

Horatia A. Remington

H. A. REMINGTON.

Let-Off Mechanism for Looms.

No. 161,901.

Patented April 13, 1875.

Fig 3.

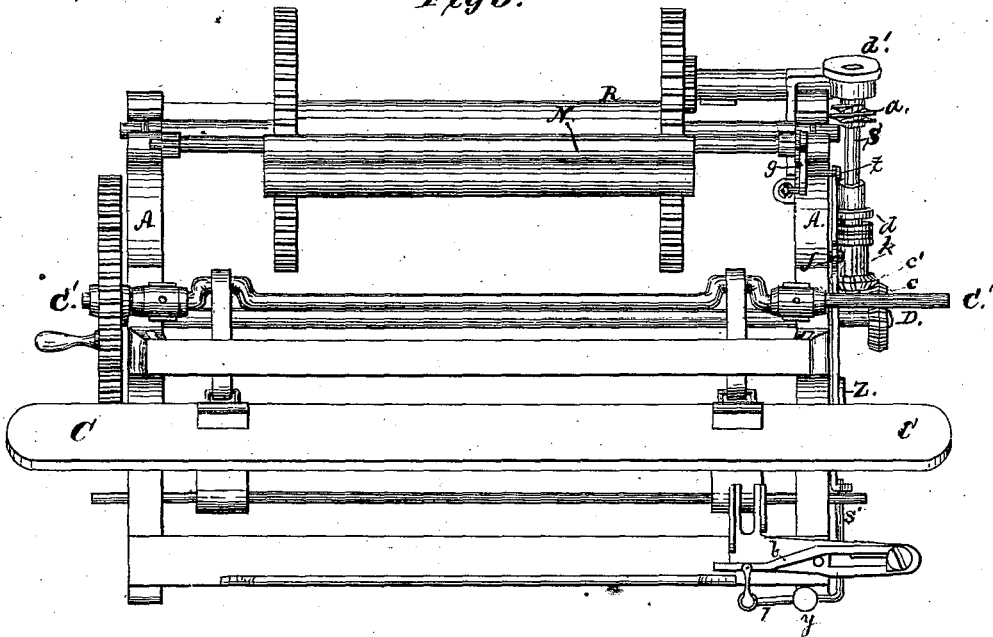

Witnesses:

Lawson Johnson  
Wm. Brayson

Inventor:

Herratia A Remington

# UNITED STATES PATENT OFFICE.

HORATIO A. REMINGTON, OF ANTHONY, RHODE ISLAND, ASSIGNOR TO S.  
COLVIN & CO., OF SAME PLACE.

## IMPROVEMENT IN LET-OFF MECHANISMS FOR LOOMS.

Specification forming part of Letters Patent No. 161,901, dated April 13, 1875; application filed  
October 19, 1874.

*To all whom it may concern:*

Be it known that I, HORATIO A. REMINGTON, of Anthony, in the county of Kent and State of Rhode Island, have invented certain Improvements in Let-Off Motions for Looms, of which the following is a specification:

The object of this invention is to deliver the warp from the yarn-beam as fast as it is required by giving motion to the beam through a feed mechanism connecting it with one of the main shafts of the loom, the closing of this connection being caused by the strain of the warp over the whip-roll; and to connect the filling stop-motion to the lever that puts the feed-motion in operation, so that no warp shall be delivered when the filling is broken or run out; and to insure the warp being held firm while the filling is being beaten up by an arm on the lathe, that prevents the feed-motion from being thrown into operation at that time.

Figure 1 shows an end elevation of a loom. Fig. 2 shows an elevation of the end of the loom to which the let-off motion is attached. Fig. 3 is a top view of the loom.

A is the end frame of the loom. C is the lathe. R is the yarn-beam. S is a short cross-shaft, turning in bearings on the end frame, and having a worm-wheel, *a*, near the back end, working in a worm-gear on the outer end of the shaft *o*, the inner end of which shaft has a small pinion, *e*, that drives the beam by a gear-wheel on its head. A bevel-gear, *c*, on the end of the cam-shaft D meshes into bevel-gear *c'* on the end of a sleeve, *k*, running loosely on the end of the shaft S, the other end of this sleeve carrying one part of a friction-clutch, the other part, *d*, of which slides on the shaft S, and drives it by a spline fast in the shaft. A lever, J, is attached to the frame by the pivot-stud *s'*, and is connected at its back end, by the rod *t*, to the arm *g* on the end of the whip-roll N. An arm, *w*, extends down from the lever J to the clutch *d*, the lower end of the arm being fitted into an annular groove in the clutch, so as to slide it upon the shaft. An upright rocker-shaft, *y*, is placed in bearings on the front of the loom, on the upper end of which is an arm, *l*, connected to the knocking-off lever *b*; and on the lower end of

the shaft is another arm, *s'*, that extends along the end of the loom, so that the free end of it, when swung toward the loom, shall be over the end of the lever J, and prevent it from riding and throwing the clutch into connection. The lever J carries a stud or friction-roll, *p*, near its front end, over which the curved end of the arm *z* on the lathe-sword swings when the lathe comes forward to beat up the filling, and thereby prevents the lever J from throwing the clutch into connection at that time, so that the yarn-beam may hold the warp firm against the beat of the lathe.

It will be seen that when the strain of the warp over the whip-roll shall be sufficient to depress the arm *g* against the force of the spring *a'*, that holds it up, the back end of the lever J will be pushed down, and the arm W will slide the clutch *d* into connection, and the shaft S will, by means of the worm-wheel gears before mentioned, turn the yarn-beam, so as to deliver warp enough to relieve the strain on the whip-roll, when the spring *a'* will throw it up, and, reversing the motion of the lever J, will throw the clutch out, so that no more warp will be turned off. Sometimes, when the filling breaks and the lever throws the belt off, the main shafts will make one or two revolutions before stopping, and the action of the harness will operate the whip-roll and let-off motion, so as to make a thin streak in the cloth. This is prevented by the arm *s'*, which swings in when the knocking-off lever operates, and prevents the lever J from sliding the clutch into connection.

One great advantage of this mechanism is, that when the loom is not running, no amount of accidental or intentional strain on the warp will draw any from the beam, and the motion of the lathe, sometimes made in tying in an end, will not alter the tension of the warp.

When it is necessary to roll up or unroll the warp it can be done by turning the eccentric *d'*, in which the rear end of the shaft S revolves, which lifts the worm out of its gear-wheel, and leaves the yarn-beam free to turn either way.

The friction-clutch may be placed where the two bevel-gear wheels *c c'* are, instead of where it is shown. In this case the clutch should be made with bevel surfaces, instead of plain, so

as to run together like bevel-gear wheel, one part sliding on the shaft like the part *d* of the present clutch.

What I claim as my invention is—

1. The shaft *S*, with clutch *d*, worm-wheel *a*, and eccentric *d'*, in combination with the lathe, angle-lever *J*, whip-roll *N*, and worm-gear wheel on the end of the shaft *o*, substantially as and for the purpose specified.

2. The rocker-shaft *y*, provided with arms *l* and *s'*, in combination with the lever *b*, lever

*J*, clutch *d*, and whip-roll *N*, substantially as and for the purpose set forth.

3. The curved arm *z*, attached to the lathe, in combination with the lever *J*, clutch *d*, and whip-roll *N*, substantially as described, and for the purpose specified.

HORATIO A. REMINGTON.

Witnesses:

LAWTON S. JOHNSON,  
WM. E. BRAYSON.